

HFD SERIES PROPORTIONAL REVERSING FAN DRIVE HIC

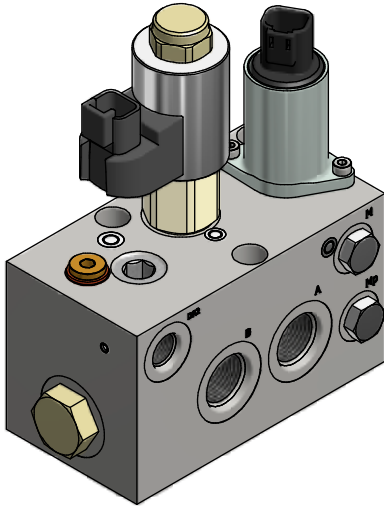

DESCRIPTION

The HFD hydraulic block controls the cooling fan speed, modulating the supply pressure to the fan motor. By actuating the Pilot Operated Directional Valve, the oil flow to the motor is reversed, permitting the de-clogging of the cooling pack, increasing its efficiency and avoiding over-heating.

FEATURES

- Best-in-Class Pressure Drop (considering the compact overall dimensions).
- Normally Closed Proportional Pressure Relief valve EE-PRB (RV) - the supply pressure decreases by increasing the current; if the current goes to zero, the fan speed goes to max (fail safe).
- Reversing Pilot Valve IP-DAR43 (EV1) - Controllable both On/Off and Proportional.
- Reversing Directional Valve - special design for soft reversing without anti-shock valves to protect the motor from pressure peaks.
- Anti-cavitation Check on the P-line (ACV).
- External pilot option (from Port M).
- Version without Proportional Pressure Relief Valve available for application with Variable Displacement Pump (contact Tecnord/Delta Power for details).

PERFORMANCE CURVES

PRESSURE DROP P->A->B->T

Hydr.Oil 26cSt [121 SSU] @ 40°C [104°F]

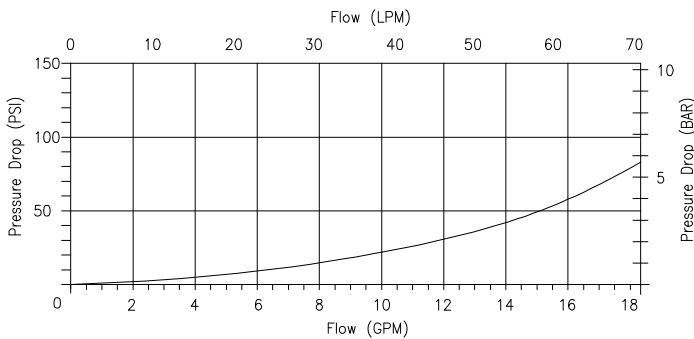

PRESSURE vs CURRENT (RV)

Hydr.Oil 26cSt [121 SSU] @ 40°C [104°F] – 12V Coil

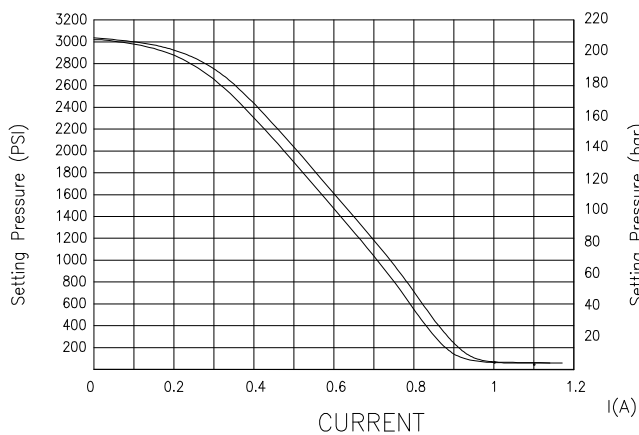

SCHEMATIC

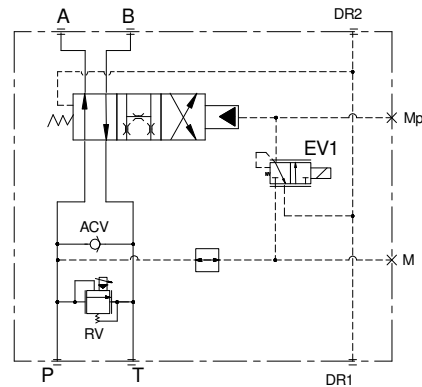

VALVE SPECIFICATIONS

Nominal Flow	A version - 20 GPM (40 LPM) B version - 40 GPM (80 LPM)
Rating Operated Pressure	3650 PSI (250 bar)
Minimum Pressure to pilot	A version - 5 bar B version - 10 bar
Coil Voltage	12V/24V
PWM Dither	150Hz
Coil Termination	Deutsch DT04-2P
Fluid Temperature Range	5° to 220°F (-15° to +105°C)
Viscosity Range	3-650 cSt
Oil Filtration Degree	18/15 (ISO 4406)
Weight	12 lbs (5.8 kg)

WARNING: the specifications/application data shown in our catalogs and data sheets are intended only as a general guide for the product described (herein). Any specific application should not be undertaken without independent study, evaluation, and testing for suitability.



4484 Boeing Drive Rockford, IL 61109 • USA • Phone +1 (815) 397-6628 • Fax +1 (815) 397-2526
mail: delta@delta-power.com • www.delta-power.com



Via Malavolti, 36 • 41122 Modena • ITALY • Phone +39 (059) 254895 • Fax +39 (059) 253512
mail: tecnord@tecnord.com • www.tecnord.com

DIMENSIONS

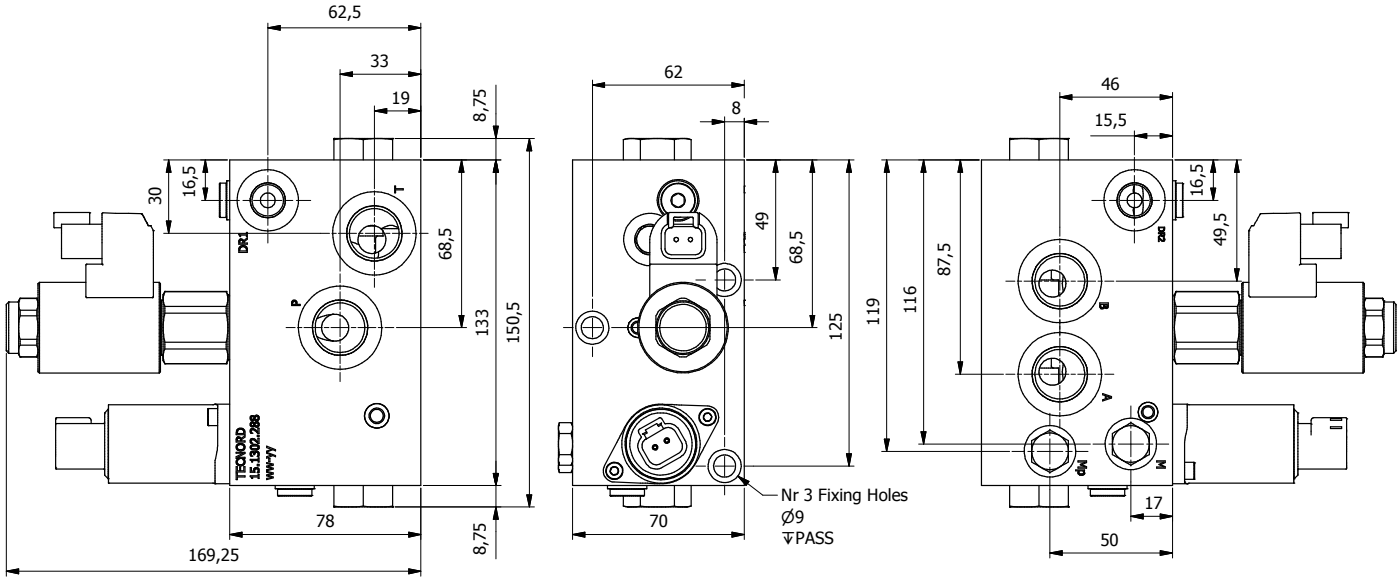

ORDERING INFORMATION

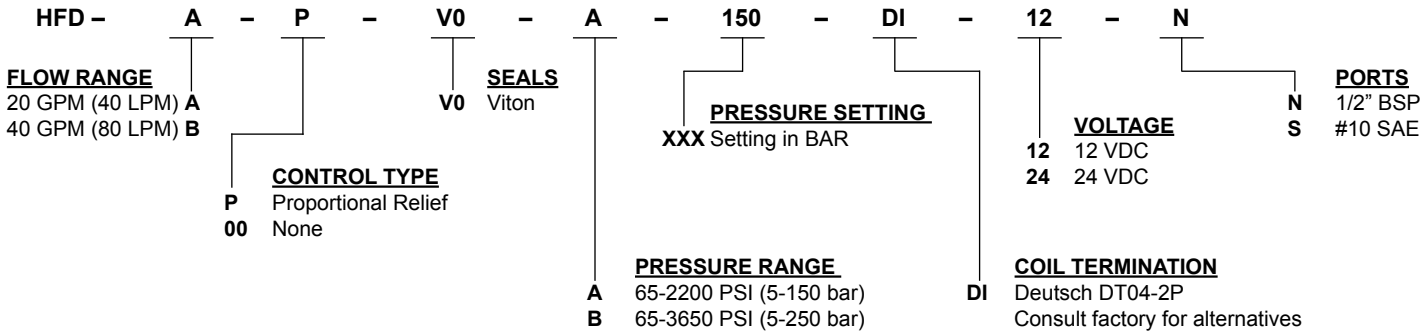

EHFD SYSTEM – ELECTRO HYDRAULIC FAN DRIVE SYSTEM

Combining the HFD hydraulic block and MMS-1012-FD Controller, Tecnord/Delta Power can provide to OEMs a complete electro-hydraulic system to control the Fan Motor.

FEATURES

- Up to 3 Temperature Inputs
- Up to 2 Digital Inputs (Switches)
- 2x PWM Output
- 3x ON/OFF Outputs
- PC-programmable
- IP67

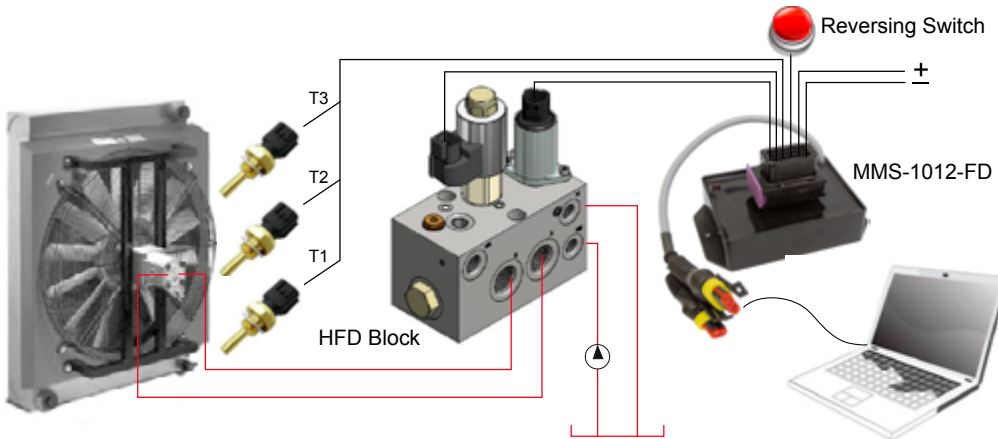

W7/2017

WARNING: the specifications/application data shown in our catalogs and data sheets are intended only as a general guide for the product described (herein). Any specific application should not be undertaken without independent study, evaluation, and testing for suitability.



4484 Boeing Drive Rockford, IL 61109 • USA • Phone +1 (815) 397-6628 • Fax +1 (815) 397-2526
mail: delta@delta-power.com • www.delta-power.com



Via Malavolti, 36 • 41122 Modena • ITALY • Phone +39 (059) 254895 • Fax +39 (059) 253512
mail: tecnord@tecnord.com • www.tecnord.com