

TECNORD

SERVOCOMANDI E REGOLAZIONE

TDV100

Directional/Proportional
Sectional Valve with Load Sense



Manufacturers of Hydraulics
and Electronic Management Systems

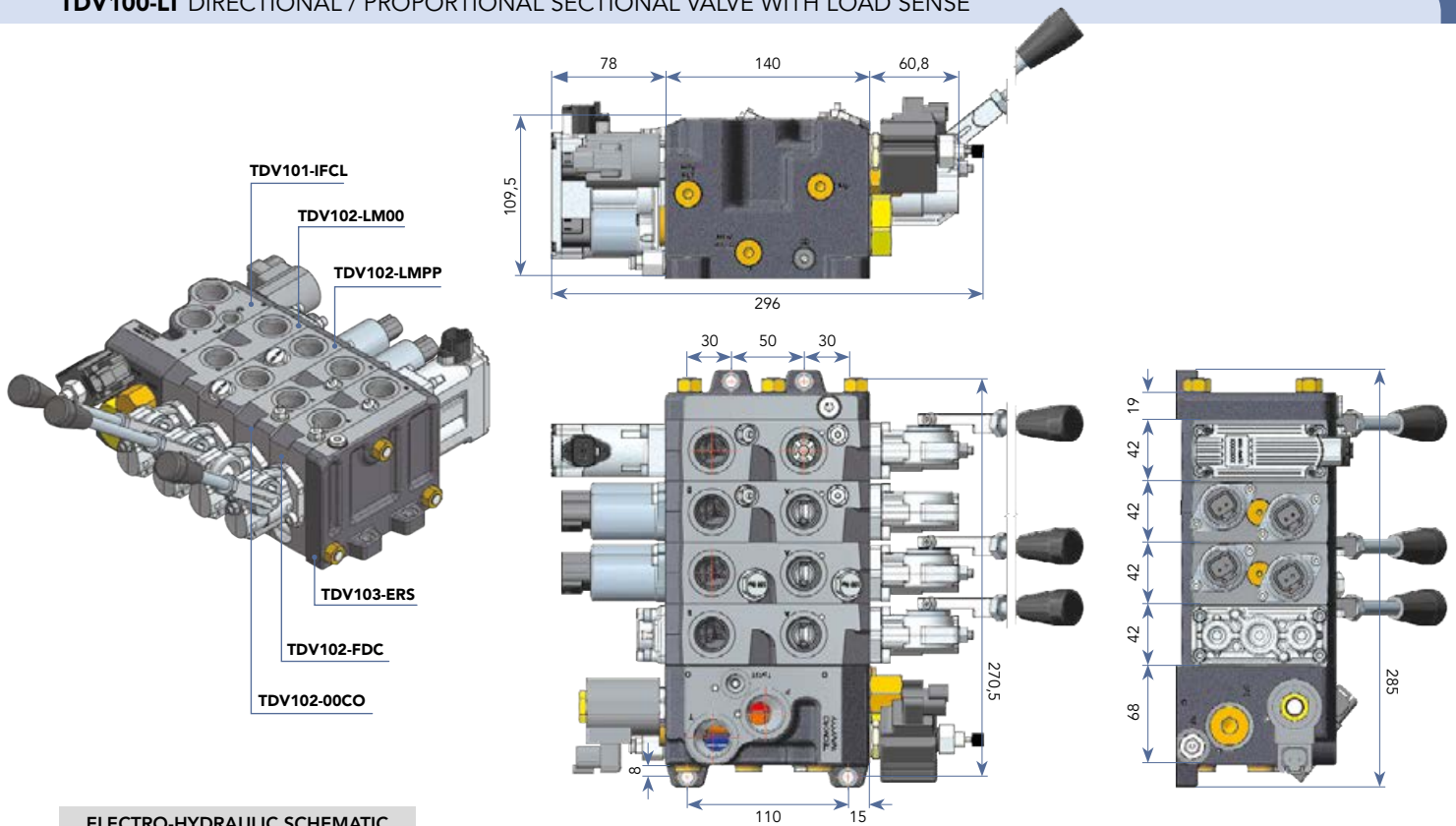

ELECTRO-HYDRAULIC SCHEMATIC

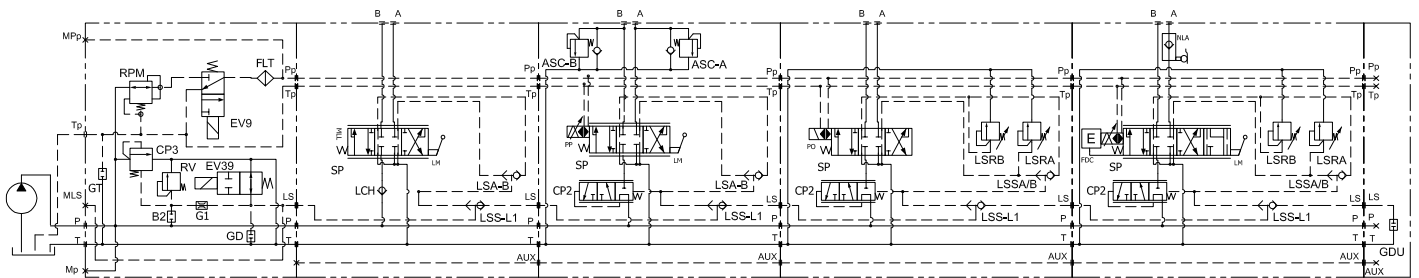

STACKABLE DIRECTIONAL CONTROL VALVE SYSTEM

The **TDV 100** is a closed center, load sensing, sectional control valve with pre-compensation. The **TDV 100** can be configured with 1 to 10 working sections and can be used either with fixed displacement or with pressure/flow compensated variable displacement pumps. When multiple functions are selected, the **TDV 100** will automatically resolve the highest function load pressure which is then transmitted to the pump or inlet unloader/by-pass compensator and drained to tank once all spools are returned to neutral. The load sensing system maintains the delta P constant through spool control notches by means of the pressure compensation principle (spool sections are equipped with local 2 ways pressure compensator). Each **TDV 100** sectional valve is crossed by a pilot pressure supply line and a return rail to feed around 20-25 bar to the MULTIDROM electro-hydraulic actuators system or proportional pilot pressure valves.

SPECIFICATIONS

- Max. operating flow..... 120 lt/min
- Max. operating flow per section..... 110 lt/min
- Max. working pressure..... 320 bar
- Min. stand-by & pilot pressure 14 bar
- Spool stroke 6 mm
- Section width 42 mm
- P & T Ports 3/4" - BSP
- A & B work ports size 1/2" - BSP
- Fluid..... Mineral based oil
- Fluid temperature range..... -25°C/+95°C
- Optimum fluid viscosity range..... 3<cSt<648
- Max. fluid contamination level..... 18/15/10 (ISO 4406)
- Seals Buna-N (Std) / Viton (Opt.)

MANUAL AND ELECTRO-HYDRAULIC CONTROLS

- TDV102-LM00** Manual control lever.
- TDV102-LMPP** Electro-hydraulic, open loop proportional control.
- TDV102-00PP** With or without manual lever.
- TDV102-LMPO** Electro-hydraulic, ON-OFF control / PO type.
- TDV102-00PO** With or without manual lever.
- TDV102-LMFD** Electro-hydraulic, closed loop proportional control.
- TDV102-00FD** With or without manual lever.

PRODUCT FEATURES AND BENEFITS

- Load-independent simultaneous control of two or more functions, within pump's flow saturation limits.
- Proportional flow control extended to 95% of spool stroke.
- MULTIDROM proportional actuators have built-in electronics requiring only variable voltage signals from a joystick.
- Internal closed loop position control configuration makes the valve spool achieving the desired position with accuracy levels approaching the performance of a servo-valve.
- Built-in CANbus interface working on SAE J1939 protocol.
- Non-feedback proportional and ON-OFF pilot pressure control actuators available.
- Electro-hydraulic, pressure compensated meter-in control of pump flow is available for cost-effective applications.
- Special "craning" spool configuration for overhung load control in conjunction with counterbalance valves.

DIMENSIONAL CHARACTERISTICS

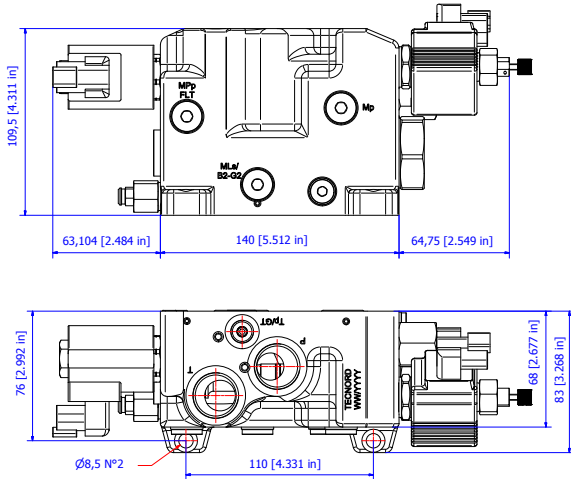

HYDRAULIC SCHEMATIC

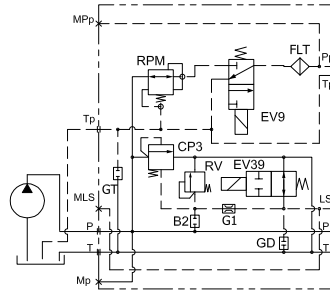

PERFORMANCE CURVES

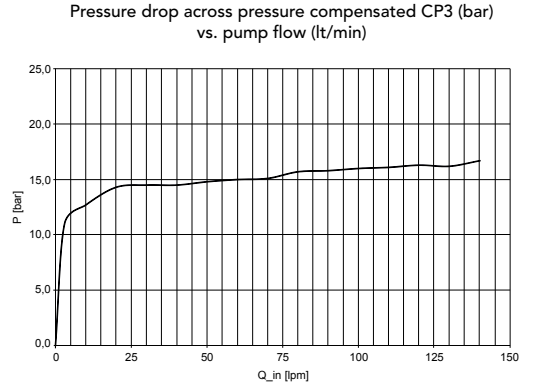

1	2	3	4	5	6	7	8
----------	----------	----------	----------	----------	----------	----------	----------

POS.	ORDERING INFORMATION	TDV101-LT	IFCLG34	R25	RPM30	EV39	EV9	12VDT	XXX/Y
1	Inlet Section Model _____								
2	Configuration and Work Ports Size _____								
3	System Relief Valve Setting _____								
4	Mechanical Pressure Reducing Valve _____								
5	2w-2p N.O. Solenoid Operated LS Signal Venting Valve _____								
6	3w-2p Solenoid Operated Pilot Pressure Cut-Off Valve _____								
7	Voltage and Solenoid Valves Coil Termination _____								
8	Last 3-digits of the 9-digits Tecnord P/N and Design Level _____								

POS.	DESCRIPTION	AVAILABLE OPTIONS
2	Configuration and Work Ports Size	ISFCLG34 Slim version / with unloader valve for fixed displ. pumps - G3/4" (BSP) ports
		ISV0LG34 Slim version / without unloader valve for variable displ. pumps - G3/4" (BSP) ports
		IFCLG34 Std. version / with unloader valve for fixed displ. pumps - G3/4" (BSP) ports
		IV0LG34 Std. version / without unloader valve for variable displ. pumps - G3/4" (BSP) ports
		ISFCLS12 Slim version / with unloader valve for fixed displ. pumps - 1.1/16"-12UNF (SAE12)
		ISV0LS12 Slim version / without unloader valve for variable displ. pumps - 1.1/16"-12UNF (SAE12)
		IFCLS12 Std. version / with unloader valve for fixed displ. pumps - 1.1/16"-12UNF (SAE12)
		IVOLS12 Std. version / without unloader valve for variable displ. pumps - 1.1/16"-12UNF (SAE12)
3	System Relief Valve Setting	Rxx Relief valve setting
4	Mechanical Pressure Reducing Valve	RPM14 Mechanical pilot pressure reducing valve for on/off control (14 bar pilot pressure)
		RPM20 Mechanical pilot pressure reducing valve for closed loop control (20 bar pilot pressure)
		RPM30 Mechanical pilot pressure reducing valve for open loop control (30 bar pilot pressure)
		TCRPM RPM Cavity plug for closed loop control (30 bar pilot pressure)
5	LS Signal Venting Valve	EV39 2w-2p N.O. solenoid operated LS signal venting valve
		TC39 Cavity plug
6	Pilot Pressure Cut-Off Valve	EV9 3w-2p solenoid operated pilot pressure cut-off valve
		TC9 Cavity plug

TDV103	END SECTION
RES	Right hand End Section
TR	Tie Rods

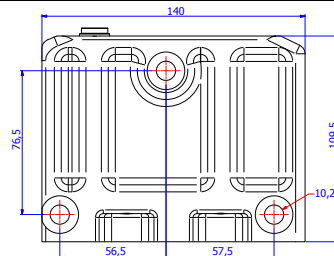

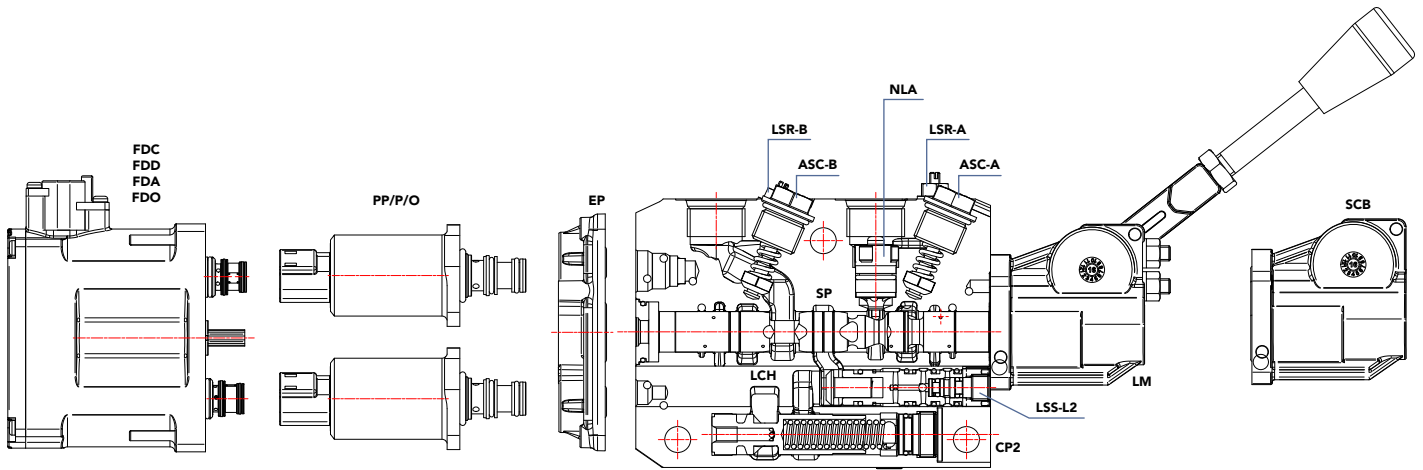

POS.	ORDERING INFO.	TDV102-LT	00CP	LMFDC	YO80	A18/B15	LSA15/B12	NLA	12VDT	G12	XXX/Y
2	Work Section Configuration	00CP		Pressure compensated							
		00CH		With load check							
		CPCH		With pressure compensator and load check							
3	Control Configuration	LM00		Manual lever							
		LMPP		Manual lever / Open loop proportional control							
		00PP		No manual lever / Open loop proportional control							
		LMPO		Manual lever / ON-OFF control							
		00PO		No manual lever / ON-OFF control							
		LMFDC		Manual lever / Closed loop proportional control / CAN version							
		00FDC		No manual lever / Closed loop proportional control / CAN version							
4	Spool Configuration/Flow Rate (see Tab. A)	XXxx		Cylinder spool (P, T, A, B blocked)							
		YOxx		Motor spool (P blocked / A&B to T)							
		YSxx		Motor spool (P blocked / A&B to T / restricted flow)							
		KAxx		Semi-motor spool (P&B blocked / A to T)							
		KBxx		Semi-motor spool (P&A blocked / B to T)							
		SExx		Single effect spool							
		ZZ		Special spool							
5	Anti-Shock/Anti-Cavitation Valves (see Tab. B)	A00/B00		No anti-shock/anti-cavitation valves							
		Axx/B00		ASC valve on A port / No ASC valve on Port B							
		A00/Byy		No ASC valve on A port / ASC valve on Port B							
		Axx/Byy		ASC valve on A&B ports							
		ATC/BTC		ASC cavity plugs on A and/or B ports							
6	LS Relief Valves on A and/or B port (see Tab. C)	LSA00/B00		No LS relief valves on A&B ports							
		LSAxx/B00		LS relief valve on A port / No LS valve on B port							
8	Voltage & Terminations	12VDT		12VDC - Deutsch DT04 connector for ON/OFF control only							
		24VDT		24VDC - Deutsch DT04 connector for ON/OFF control only							
9	Ports Size	G12		A&B ports: 1/2" - BSP							
		S10		A&B ports: 7/8"-14UNF (SAE10) Option available on request							

TAB. A	Spool Metering Characteristics			
10=	0 to 10 lt/min	60=	0 to 60 lt/min	
20=	0 to 20 lt/min	80=	0 to 80 lt/min	
40=	0 to 30 lt/min	100=	0 to 100 lt/min	

TAB. B	Anti-Shock Valves Setting			
A00=	No port relief	B00=	No port relief	
A07=	Port A/70 bar	ATC=	Cavity plug on A	
B28=	Port B/280 bar	BTC=	Cavity plug on B	

TAB. C	LSA/LSB Relief Valves Setting			
LSA00	No LS relief	LSB00	No LS relief	
LSA12	120 bar	LSB08	80 bar	
LSA25	250 bar	LSB28	280 bar	

Port relief valve standard settings: 70-100-120-140-160-180-200-220-240-260-280 Different settings available on request

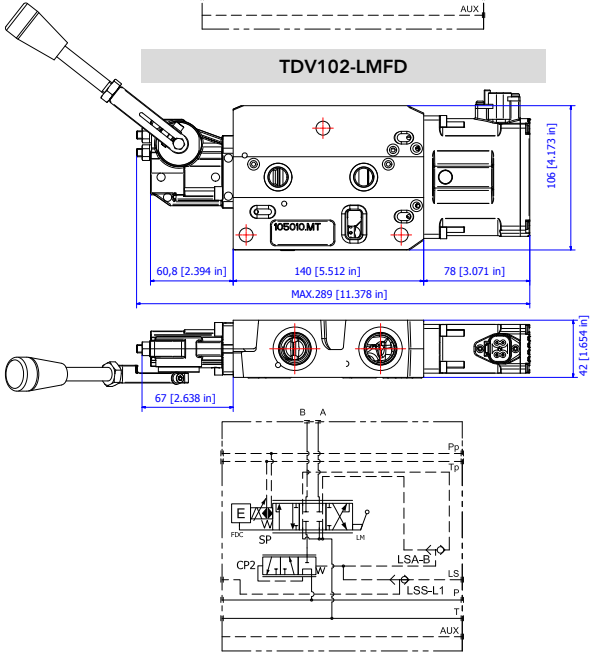
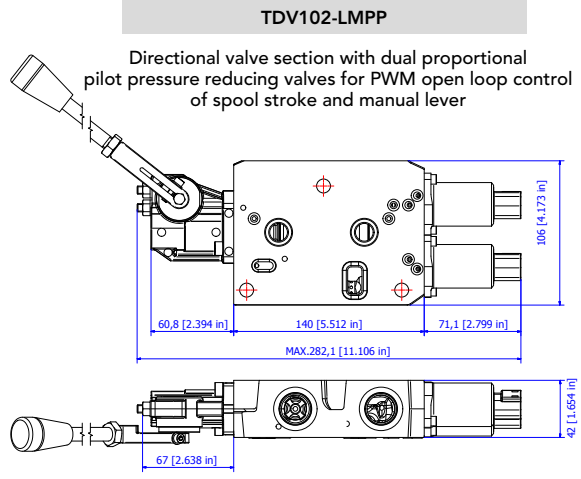
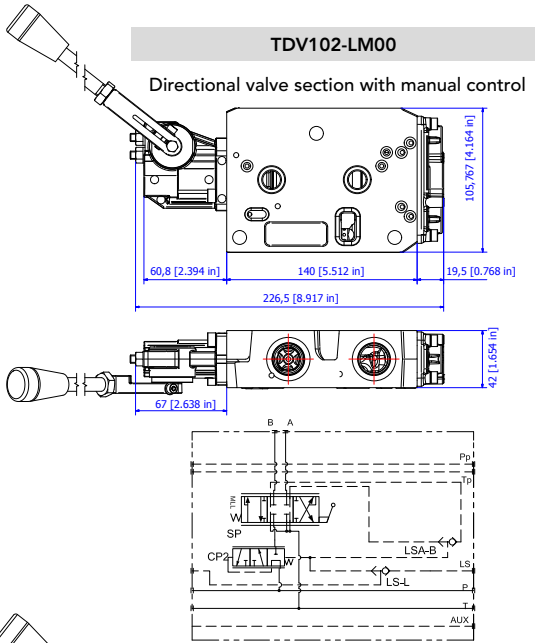

OPTION FEATURES

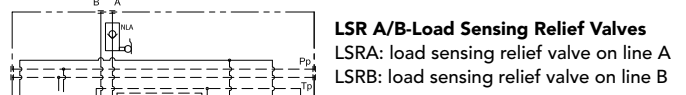
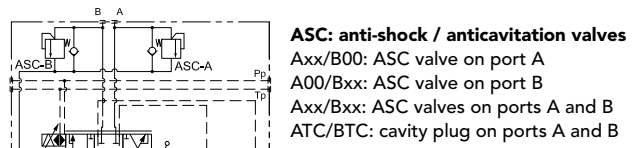

NLA: no-leak valve on port A

FL: 4th position FLOAT

TDV102 - WORK SECTION PERFORMANCE CURVES

Work port flows vs. spool travel & various control parameters

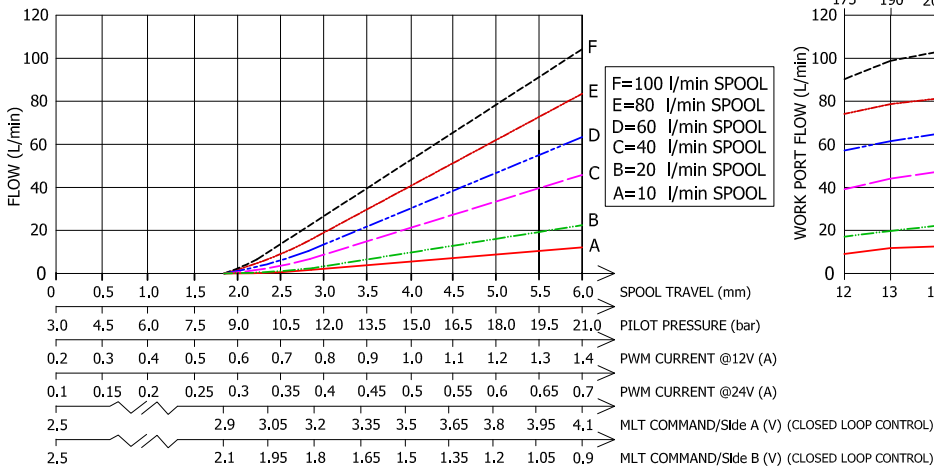

Spool flows vs. differential pressure

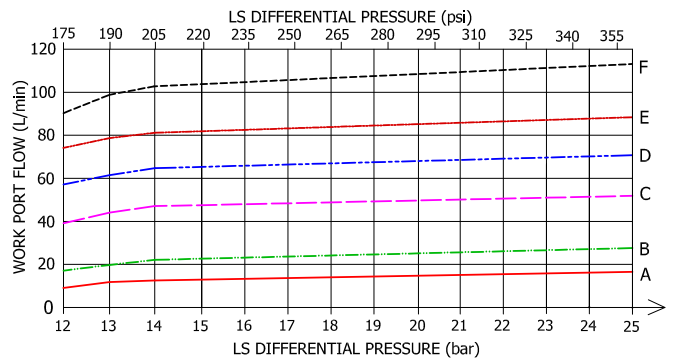



PRINCIPLE OF OPERATION

The **MLT-FD5/D** electro-hydraulic proportional actuator has been designed to shift a directional control valve spool either directly (**FL version**) or by means of a servo-piston mechanically connected to it (**SP version**). The internal closed loop position control configuration of the **MLT-FD5/D** makes the valve spool achieve the desired position with accuracy levels approaching the performance of a servo-valve, by continuously comparing the set-point of a remote control device (**Potentiometer, Joystick, Machine Management System**) with the feed-back signal generated by a high-precision hall effect position transducer.

Vin from 2.75 to 4.1V. At Vin = 4.50V, the spool is brought into its **FLOAT POSITION**, if present. By decreasing the input voltage from 4.1 to 2.75V, the spool stroke is linearly reduced and after the oil flow is fully shut-off, a step-down from **MINIMUM FLOW** to **NEUTRAL** position takes place.

SPOOL STROKE A

When the input voltage signal fed to the MLT-FD5 actuator is maintained within 2.25 and 2.75V, the directional valve spool is at rest (Neutral Dead Band). When Vin = 2.75V, the spool steps up from **NEUTRAL** to **MINIMUM FLOW** control position. A linear ramp from **MIN.** to **MAX.** spool stroke will follow by increasing

SPOOL STROKE B

Same as for **STROKE A**, by varying Vin from 2.25 to 0.9V, the spool will go from **NEUTRAL** to **MAX. STROKE** in the opposite direction.

ALARM / FAIL - SAFE MODE

An input voltage variation beyond the calibration range (<0.25V or >4.75V) will bring the system into an **ALARM** mode, urging the spool to return to its **NEUTRAL** position until Vin is brought back to its nominal control range.

HYDRAULIC SPECIFICATIONS

- Max. supply pressure..... 35 bar
- Min. supply pressure..... 12 bar
- Max. back pressure..... 1.5 bar
- Pilot flow requirement 0.2 lt/section
- Oil temperature range..... -20/+95°C
- Oil viscosity range..... 3-650 cSt
- Filtration..... 18/15/10 (ISO 4406)

ELECTRICAL SPECIFICATIONS

- Operating voltage..... 8-30 VDC
- Max. current consumption.... 750mA/section
- Operating temperature -20/+105°C
- Analog input impedance..... >40 kOhm
- Typical ctrl pot. resistance 1-10 kOhm
- Analog input signal 0-5V
- Degree of protection..... IP 68

CONNECTOR PINOUT (FRONT VIEW)

D/A0

1. + Power Supply
2. Do not Connect
3. Control Signal
4. - Power Supply (GND)

D/AF

1. + Power Supply
2. Sensor Feedback Output
3. Control Signal
4. - Power Supply (GND)

O/12 - O/24

1. + Power Supply coil A
2. - Power Supply (GND) coil A
3. + Power Supply coil B
4. - Power Supply (GND) coil B

D/A5

1. + Power Supply
2. + 5V Aux. Supply voltage
3. Control Signal
4. - Power Supply (GND)

D/C0

1. + Power Supply
2. CANL
3. CANH
4. - Power Supply (GND)

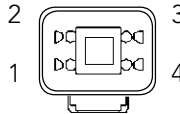

VALVE SPOOL STROKE (mm) VS. INPUT SIGNAL (Volt DC)

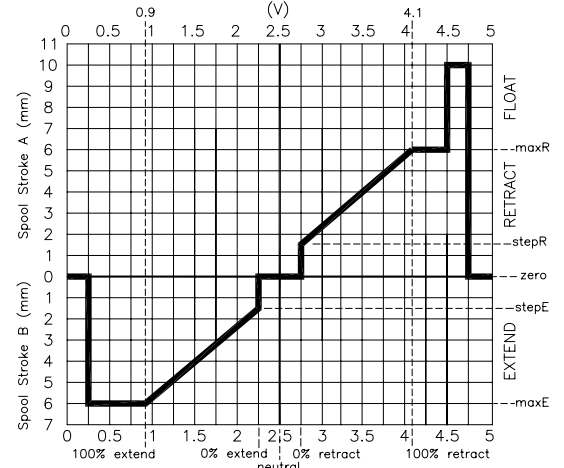

AVAILABLE CONFIGURATIONS AND MODEL DESIGNATION

MLT/FD5-D/A0

Proportional actuator
Digital electronics
Analog control signal
(e.g. Potentiometer)

+5V auxiliary power supply for the control potentiometer

MLT/FD5-D/AF

Proportional actuator
Digital electronics
Analog control signal
(e.g. Potentiometer)
Feedback output
(spool position): 0-5V

MLT/FD5-D/C0

Proportional actuator
Digital electronics
CANbus control (J1939)

MLT/FD5-0-12

On/Off actuator, 12V coils

MLT/FD5-0-24

On/Off actuator, 24V coils

ORDERING INFORMATION

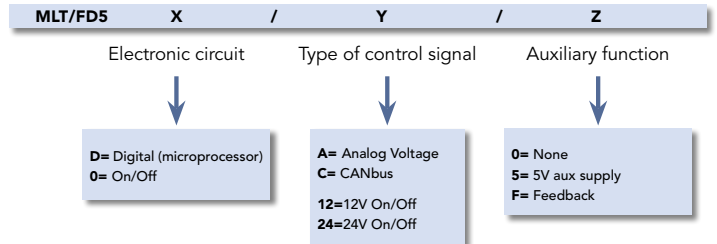

OPEN LOOP / PP-PILOT PRESSURE CONTROL PROPORTIONAL ACTUATOR

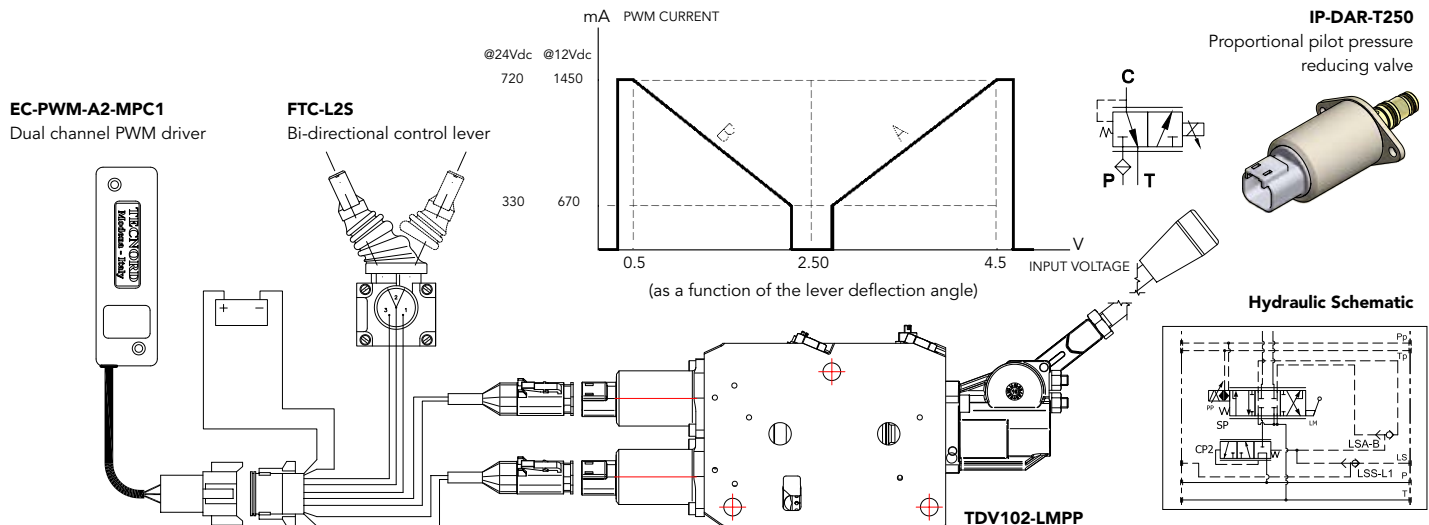

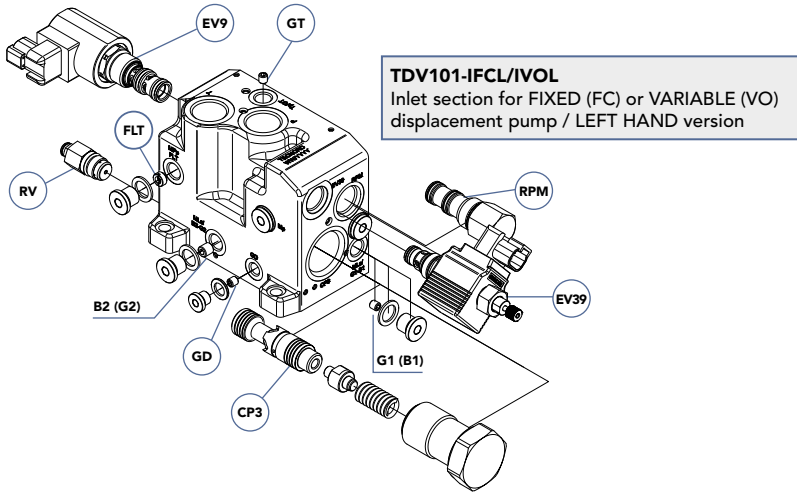
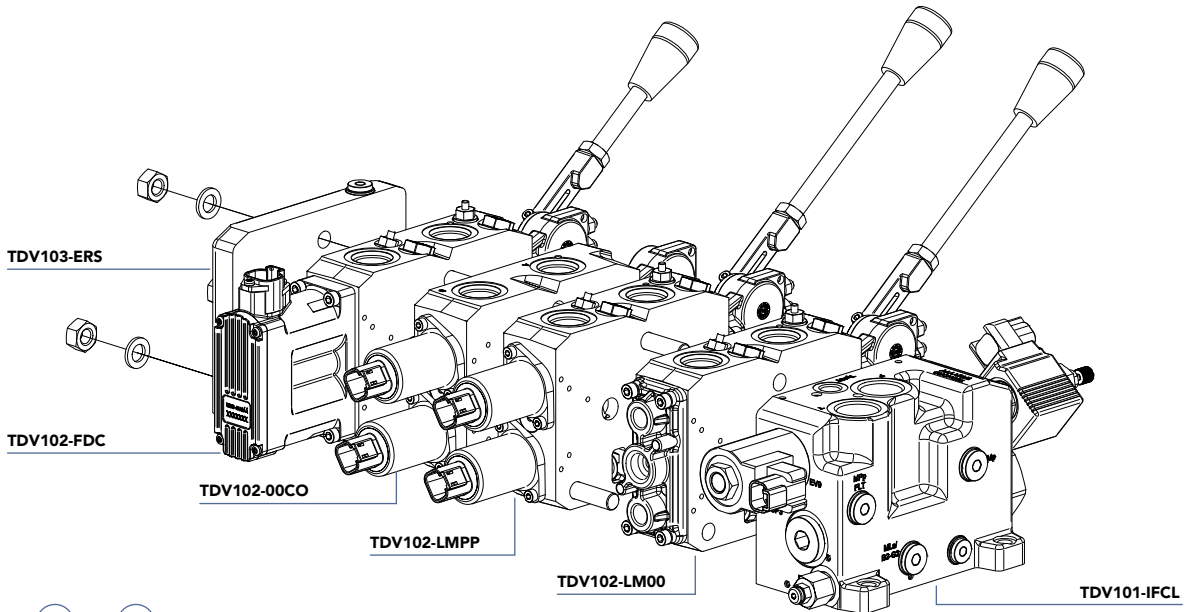

TDV101-IFCL/IVOL
Inlet section for FIXED (FC) or VARIABLE (VO) displacement pump / LEFT HAND version

POSITION	DESCRIPTION
TDV101-LT	LH INLET SECTION
CP3	By-pass pressure compensator
GT	Blank plug / Tp to T connection
GD	Bleed off orifice
G1	Orifice (fixed displacement pumps)
B2	Blank plug (fixed displacement pumps)
G2	Orifice (variable displacement pumps)
B1	Blank plug (variable displacement pumps)
RV	LS signal relief valve (system relief valve)
EV39	2w-2p N.O. solenoid op. LS venting valve
RPM	Mechanical pilot pressure reducing valve
EV9	3w-2p solenoid op. pilot pressure dump valve
FLT	Pilot pressure line filter screen

TDV102
Work section / Pressure compensated with or without electro-hydraulic actuators

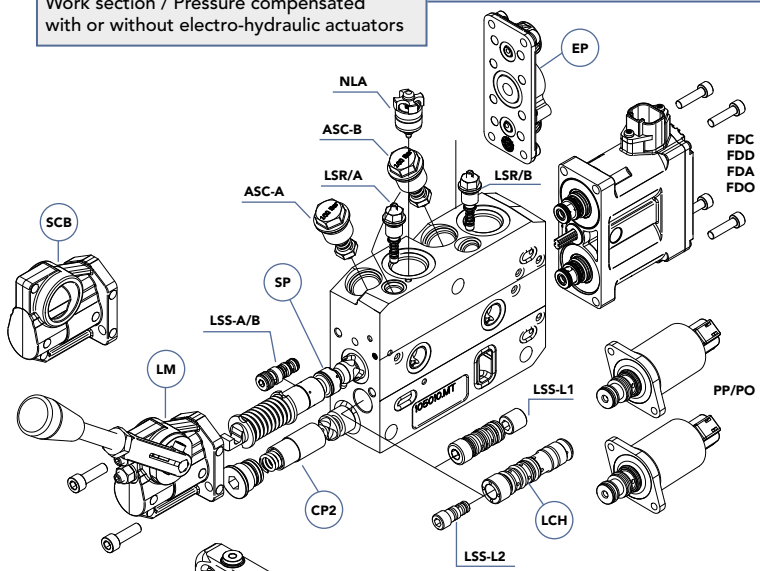

TDV102-LT	WORK SECTION
CP2	Pressure compensator/Reducer
LCH	Load check
SP	Directional spool
ASC-A/B	Anti-shock/Anti-cavitation valves A/B ports
LSR-A/B	LS relief valve A/B lines
LSS-L1	LS shuttle valve - LS common line/Type 1
LSS-L2	LS shuttle valve - LS common line/Type 2
LSS-A/B	LS Shuttle valve A/B lines
LM	Manual lever control
SCB	Spring cover block w/o manual lever mechanism
NLA	No-leak valve - Port A only
EP	End plate/Blank
PP	Proportional pressure control
PO	ON-OFF control/PO type
FDC	Closed loop control/CAN version
FDD	Closed loop control/Digital version
FDA	Closed loop control/Analog version
FDO	ON-OFF control/FO type

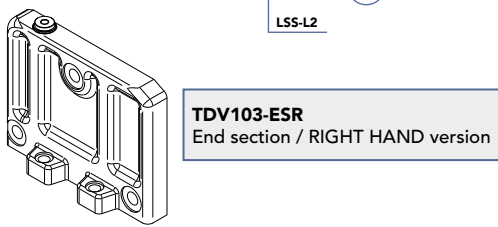

TDV103-ESR
End section / RIGHT HAND version

TDV103-LT	RH END SECTION
ESR	End section/Blank
TR	Tie rods

TECNORD

COMPREHENSIVE RANGE OF REMOTE CONTROL ELECTRONICS



EC-PWM-A1-MPC1

Microprocessor - based PWM electronic drivers



FINGERTIP PROPORTIONAL LEVERS

Potentiometric and hall effect single-axis control levers and roller switches



ERGONOMIC GRIPS

Multi-function ergonomic grips with on-off and proportional switches



HEAVY DUTY JOYSTICKS

Potentiometric and hall effect multi-axes control joysticks



EC - MMS

Microprocessor-based Machine Management Systems for the integrated control of electro-hydraulic and safety functions



ECOMATIC

GPS ground-speed oriented salt spreader control systems



RC - SHW

Combined on-off and proportional radio control system with single hand wander



RC - PTM

Multi-function proportional Radio Control with shoulder-strap transmitter and CANbus receiver



ARM-REST CONTROLLER

Arm-rest control unit for Hedge Cutter



TECNORD

Via Malavolti, 36 - 41122 Modena - Italy - Tel. +39 (059) 254895 - Fax +39 (059) 253512
tecnord@tecnord.com - www.tecnord.com