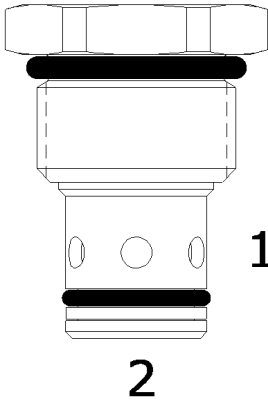

DE-CVS DIRECT ACTING CHECK VALVE, SOFT SEAT, POPPET

DESCRIPTION

10 size, 7/8-14 thread, "Delta" series, soft seat check valve.

OPERATION

The DE-CVS allows flow to pass from (2) to (1) and blocks flow from (1) to (2). The cartridge has a fully guided check poppet, which is spring-biased closed until sufficient pressure is applied at (2) to open to (1).

FEATURES

- Soft seat for ultra low leakage.
- Industry common cavity.
- Optional bias springs for backpressure application flexibility.

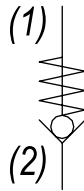
HYDRAULIC SYMBOL

Drop-In pilot pistons are NOT RECOMMENDED for this valve. If you would like to create P.O. Check Valve Function, please use the CVA valve and/or see the Hydraulic Integrated Circuits section for details.

PERFORMANCE

Actual Test Data (Cartridge Only)

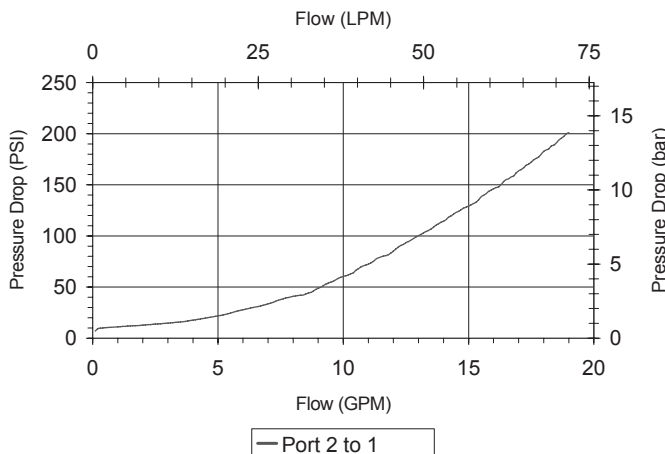
VALVE SPECIFICATIONS

Nominal Flow	10 GPM (38 LTR/N)
Rated Operating Pressure	1000 PSI (70 bar)
Typical Internal Leakage (150 SSU)	Negligible
Viscosity Range	36 to 3000 SSU (3 to 647 cSt)
Filtration	ISO 18/16/13
Media Operating Temp. Range	-32° to 160°F (0° to 70°C)
Weight	.14 lbs (.06 kg)
Operating Fluid Media	General Purpose Hydraulic Fluid
Cartridge Torque Requirements	30 ft-lbs (40.6 Nm)
Cavity	DELTA 2W
Cavity Form Tool (Finishing)	40500000
Seal Kit	21191200

DIMENSIONS

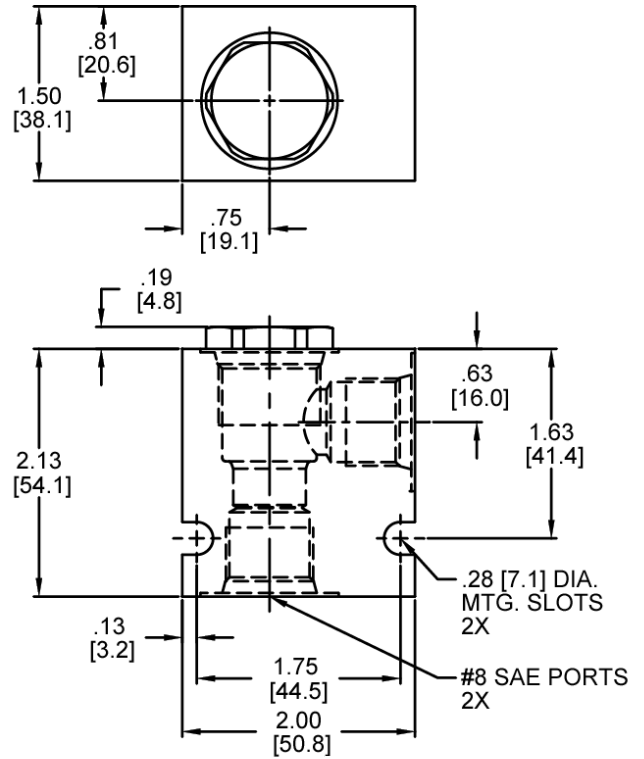
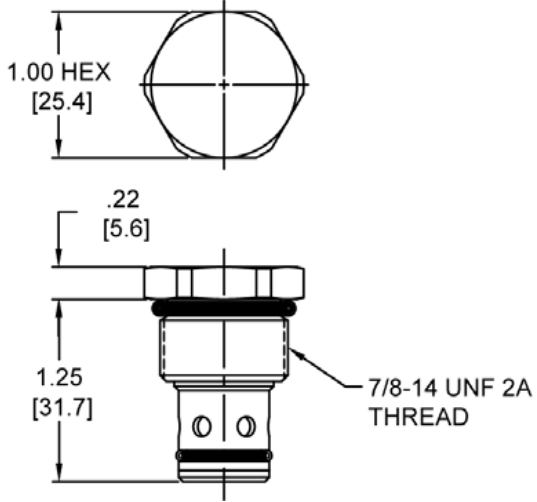

Body Weight: .47 lbs (.21 kg)

ORDERING INFORMATION

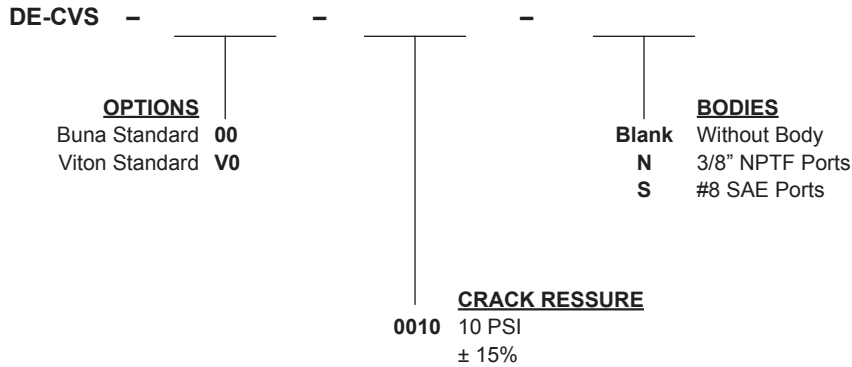

WARNING: the specifications/application data shown in our catalogs and data sheets are intended only as a general guide for the product described (herein). Any specific application should not be undertaken without independent study, evaluation, and testing for suitability.