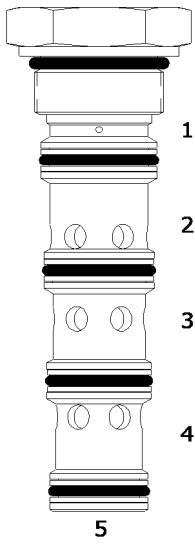

**SO-PTS PILOT TO SHIFT, 3 WAY VALVE, OPEN TRANSITION**

**DESCRIPTION**

16 size, 1 5/16 -12 thread, "SIXTEEN" series, pilot to shift, 3 way valve, open transition.

**OPERATION**

In neutral the SO-PTS allows flow between ports (3) and (4), port (2) is blocked. With application of a remote pilot signal at (5), the valve's spool shifts to allow flow between ports (2) and (3), while port (4) is blocked. During transition ports (2), (3), and (4) are open. The spring chamber is vented to the tank through port (1). The vented spring chamber allows the valve to be fully pressurized at ports (2), (3), and (4) without affecting required pilot pressure. Pressure at (1) will affect required pilot pressure.

**FEATURES**

- Hardened parts for long life.
- Industry common cavity.

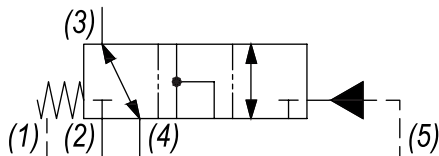
**HYDRAULIC SYMBOL**

*A rate limiting orifice less than .060" diameter is recommended at port (5).*

**PERFORMANCE**

Actual Test Data (Cartridge Only)

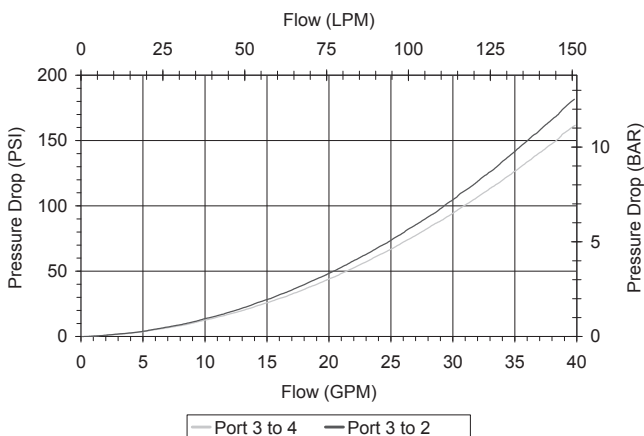
**VALVE SPECIFICATIONS**

Nominal Flow	40 GPM (151 LTR/M)
Rated Operating Pressure	3500 PSI (241 bar)
Typical Internal Leakage (150 SSU)	10 cu in/min (164 ml/min)
Viscosity Range	36 to 3000 SSU (3 to 647 cSt)
Filtration	ISO 18/16/13
Media Operating Temp. Range	-40° to 250°F (-40° to 120°C)
Weight	1.11 lbs (.50 kg)
Operating Fluid Media	General Purpose Hydraulic Fluid
Cartridge Torque Requirements	90 ft-lbs (122 Nm)
Cavity	SIXTEEN 5W SHORT
Cavity Form Tool (Finishing)	40500020
Seal Kit	21191410

**WARNING:** the specifications/application data shown in our catalogs and data sheets are intended only as a general guide for the product described (herein). Any specific application should not be undertaken without independent study, evaluation, and testing for suitability.

**DIMENSIONS**

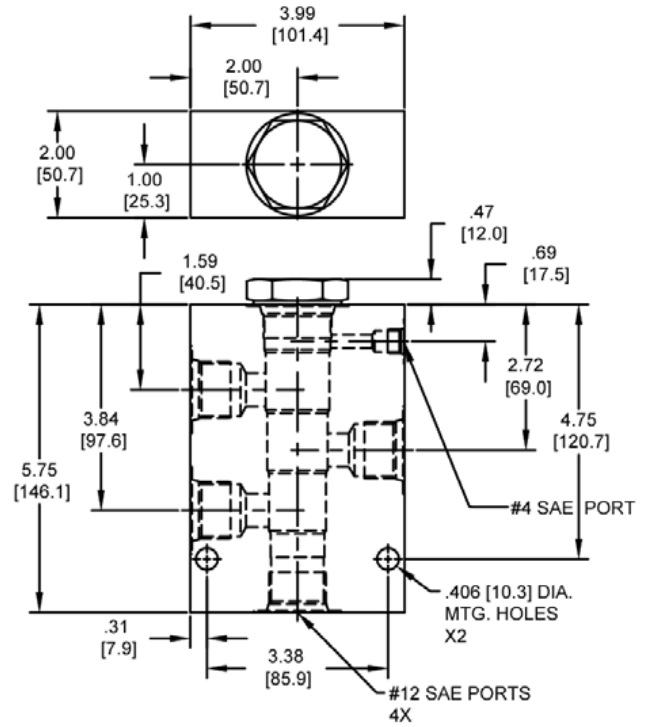
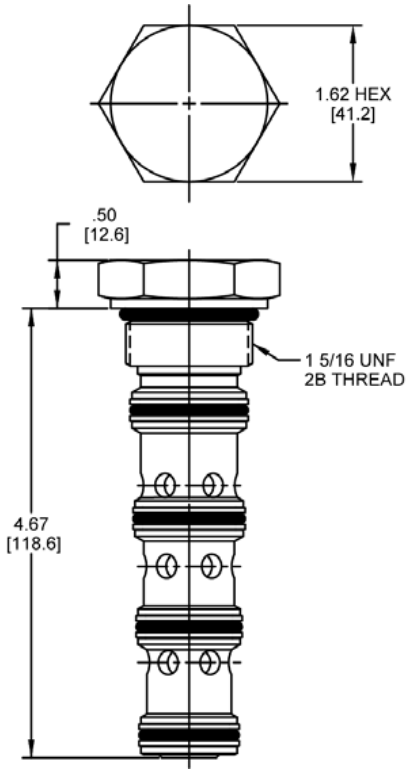

Body Weight: 3.76 lbs (1.62 kg)

**ORDERING INFORMATION**

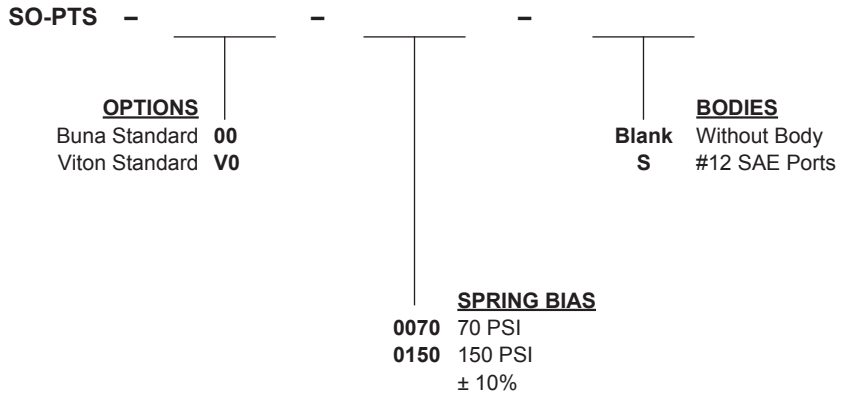

W/51 / 12-2022

**WARNING:** the specifications/application data shown in our catalogs and data sheets are intended only as a general guide for the product described (herein). Any specific application should not be undertaken without independent study, evaluation, and testing for suitability.