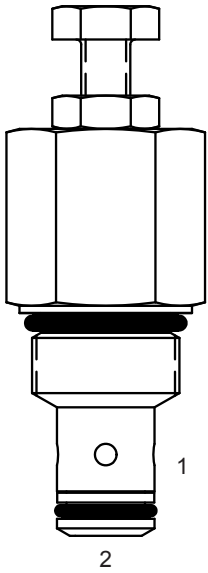

**PB-FCA ADJUSTABLE FLOW CONTROL VALVE, PRESSURE COMPENSATED**

**DESCRIPTION**

8 size, 3/4-16 thread, "Power" series, pressure compensated, flow control valve.

**OPERATION**

The cartridge maintains a constant flow rate out of (1) regardless of load pressure changes in the circuit downstream of (1). The adjustable control differential spring load can be set to customer flow specification (see options for ranges). The valve begins to respond to load changes when the flow through the valve creates a pressure differential from (2) to (1), greater than 200 PSI (14 bar), with accurate flow maintenance from 200 to 3500 PSI (14 to 241 bar). Reverse flow (1) to (2) returns through the control orifice and is non-compensated. The regulated flow increases from low to high with clockwise rotation of the knob.

**FEATURES**

- Hardened parts for long life.
- Industry common cavity.
- Fine low-torque adjustment.

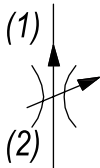
**HYDRAULIC SYMBOL**

*Best stability is obtained with adjustment at highest flow.*

**PERFORMANCE**

Actual Test Data (Cartridge Only)

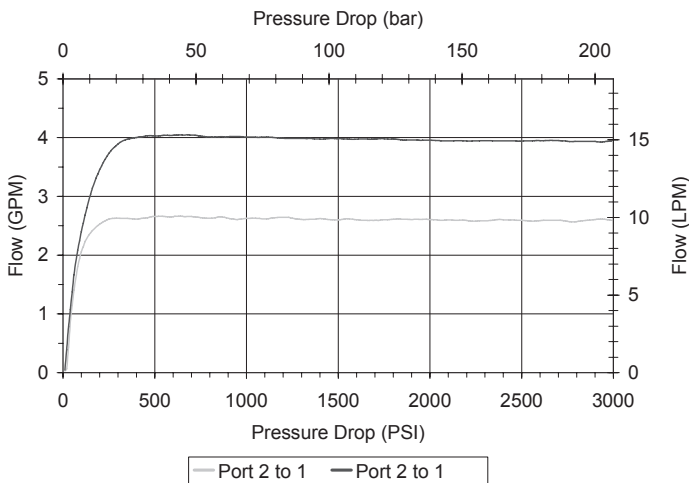
**VALVE SPECIFICATIONS**

Nominal Flow	4 GPM (15 LPM)
Rated Operating Pressure	3500 PSI (241 bar)
Viscosity Range	36 to 3000 SSU (3 to 647 cSt)
Filtration	ISO 18/16/13
Media Operating Temp. Range	-40° to 250°F (-40° to 120°C)
Weight	.26 lbs (.12 kg)
Operating Fluid Media	General Purpose Hydraulic Fluid
Cartridge Torque Requirements	25 ft-lbs (34 Nm)
Cavity	POWER 2W
Cavity Form Tool (Finishing)	40500005
Seal Kit	21191100

**WARNING:** the specifications/application data shown in our catalogs and data sheets are intended only as a general guide for the product described (herein). Any specific application should not be undertaken without independent study, evaluation, and testing for suitability.

**DIMENSIONS**

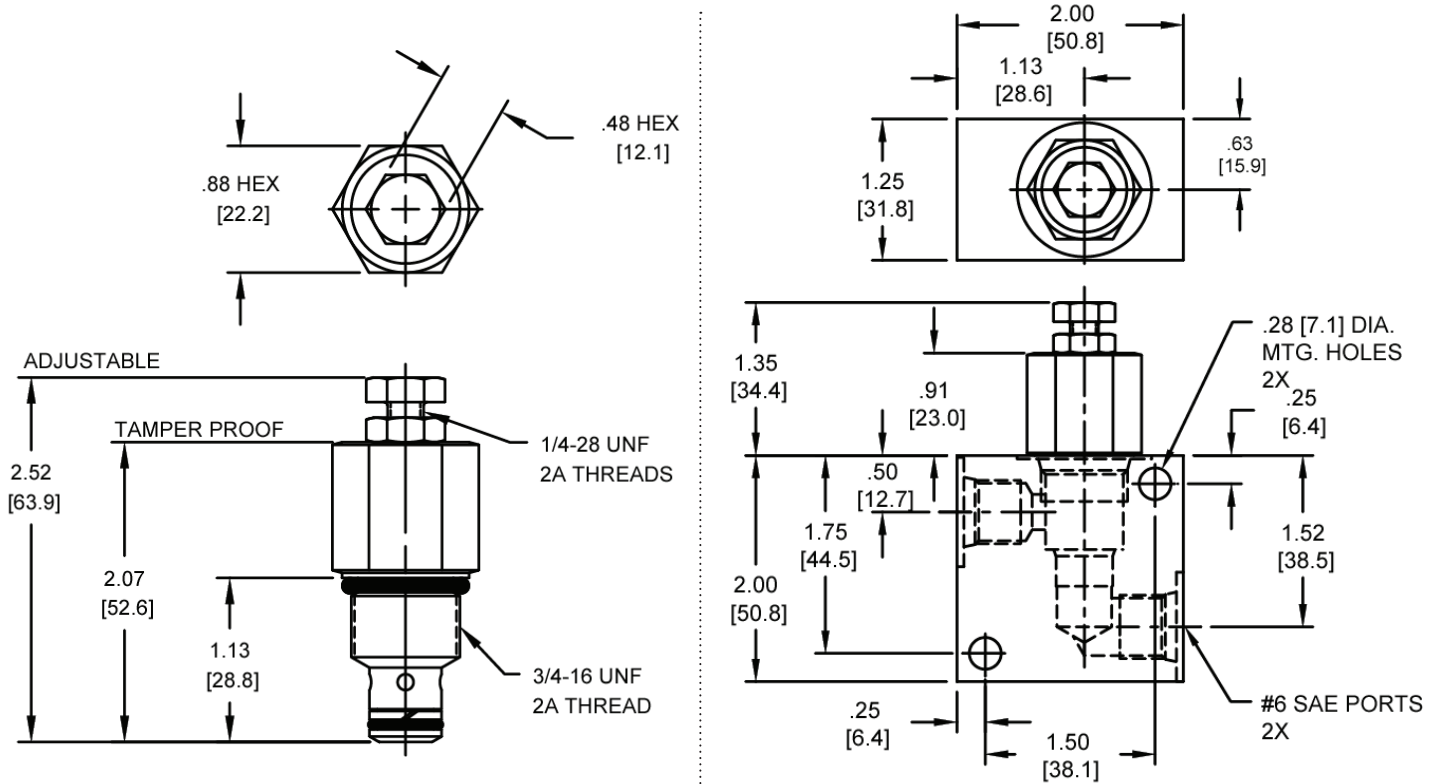

Body Weight: .39 lbs (.18 kg)

**ORDERING INFORMATION**

<p><b>PB-FCA</b> - - -</p> <p><b>OPTIONS</b></p> <p>Buna Standard <b>00</b></p> <p>Viton Standard <b>V0</b></p> <p>Buna, Tamper Proof <b>0T</b></p> <p>Viton, Tamper Proof <b>VT</b></p>	<p><b>BODIES</b></p> <p><b>Blank</b> Without Body</p> <p><b>N</b> 1/4" NPTF Ports</p> <p><b>S</b> #6 SAE Ports</p>
<p><b>FLOW</b></p> <p><b>0.45</b> .25 - .45 GPM</p> <p><b>0.75</b> .45 - .75 GPM</p> <p><b>1.35</b> .75 - 1.35 GPM</p> <p><b>2.65</b> 1.35 - 2.65 GPM</p> <p><b>4.00</b> 2.65 - 4.00 GPM</p>	

**Tamper Proof**  
 Fill in Digit Pressure Setting  
 Example: 02.0 - 2 GPM

W-51 / 12-2022

**WARNING:** the specifications/application data shown in our catalogs and data sheets are intended only as a general guide for the product described (herein). Any specific application should not be undertaken without independent study, evaluation, and testing for suitability.