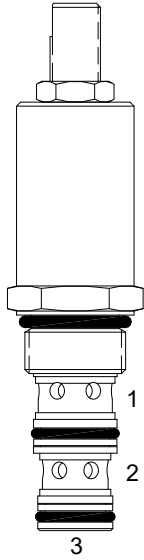

PP-FCQ ADJUSTABLE PRIORITY FLOW CONTROL VALVE

DESCRIPTION

8 size, 3/4-16 thread, "Power" series, adjustable priority flow control valve.

OPERATION

The PP-FCQ allows pressure compensated flow from (3) to (1) regulated by the pressure present at (3). Excess flow bypasses out (2).

FEATURES

- Hardened parts for long life.
- Industry common cavity.

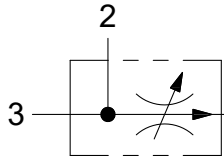
HYDRAULIC SYMBOL

Test data shown on this sheet, for condition of port (2) to tank. Data on next page, for condition of port (3) to tank.

PERFORMANCE

Actual Test Data (Cartridge Only)

VALVE SPECIFICATIONS

Nominal Flow	5 GPM (19 LPM)
Rated Operating Pressure	3500 PSI (241 bar)
Viscosity Range	36 to 3000 SSU (3 to 647 cSt)
Filtration	ISO 18/16/13
Media Operating Temp. Range	-40° to 250°F (-40° to 120°C)
Weight	.56 lbs (.25 kg)
Operating Fluid Media	General Purpose Hydraulic Fluid
Cartridge Torque Requirements	25 ft-lbs (33.8 Nm)
Cavity	POWER 3W
Cavity Form Tool (Finishing)	40500024
Seal Kit	21191106

DIMENSIONS

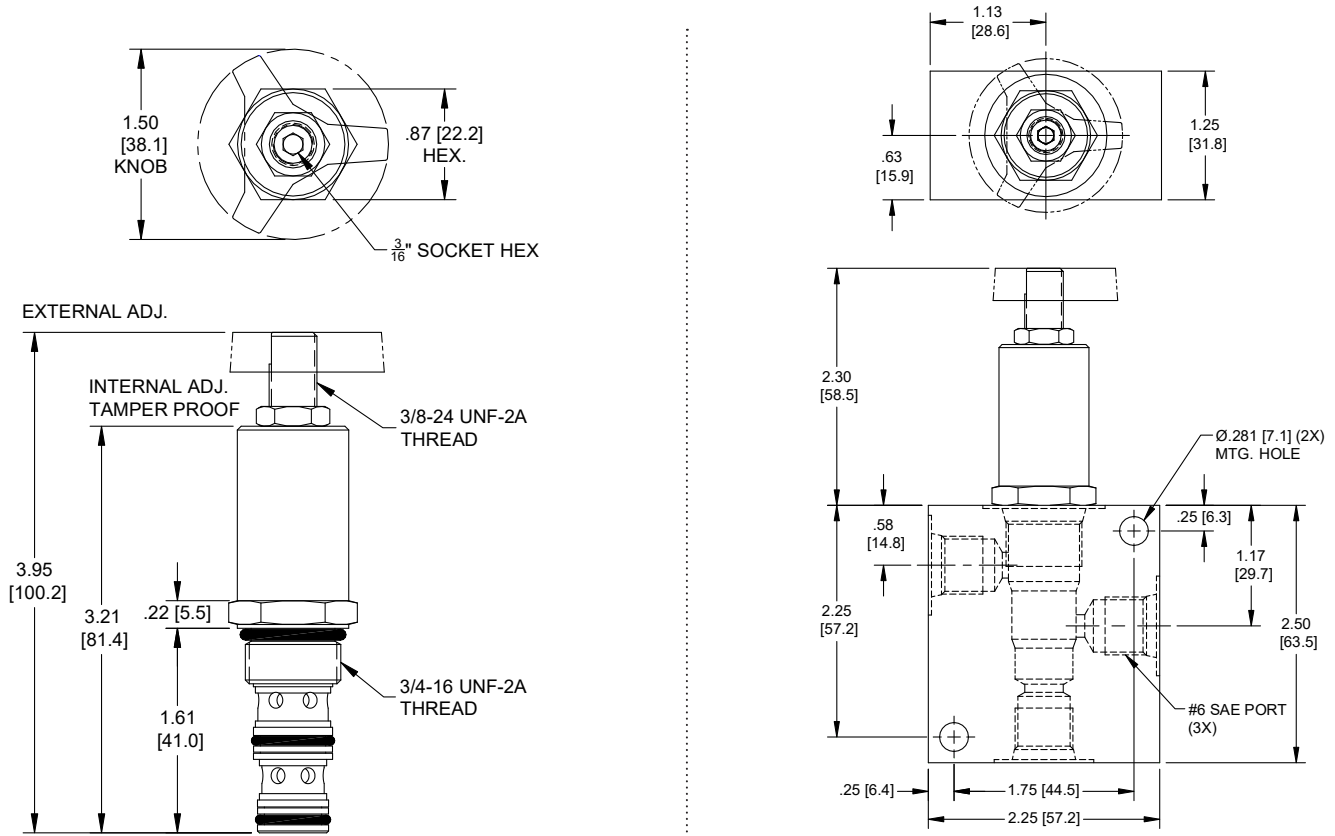

Body Weight: .56 lbs (.25 kg)

ORDERING INFORMATION

PP-FCQ - - - -

OPTIONS

- External Adjust w/Locknut, Buna **00**
- External Adjust w/Locknut, Viton **V0**
- Knob, Buna **0K**
- Knob, Viton **VK**
- Internal Adjust, Buna **0I**
- Internal Adjust, Viton **VI**
- Tamper Proof, Buna **0T**
- Tamper Proof, Viton **VT**

BODIES

- Blank Without Body
- N** 1/4" NPTF Ports
- S** #6 SAE Ports

FLOW

- 0.50** .25 - .50 GPM
- 0.75** .50 - .75 GPM
- 1.25** .75 - 1.25 GPM
- 2.50** 1.25 - 2.50 GPM
- 5.00** 2.50 - 5.00 GPM

Tamper Proof

Fill in 4 Digit Flow Setting
Example: 01.0 - 1.0 GPM

WARNING: the specifications/application data shown in our catalogs and data sheets are intended only as a general guide for the product described (herein). Any specific application should not be undertaken without independent study, evaluation, and testing for suitability.