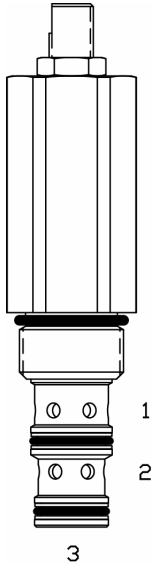

**DF-PCE ADJUSTABLE PRESSURE COMPENSATING VALVE, BYPASS TYPE**

**DESCRIPTION**

10 size, 7/8-14 thread, "Delta" series, spring adjustable pressure compensating valve, bypass type.

**OPERATION**

The DF-PCE with an external orifice in parallel with ports (3) and (1) maintains a constant flow rate across the external orifice, regardless of load pressure changes in the system upstream of (3), or in the bypass leg at (2) as long as pressure at (2) is greater than (1). The valve's spool maintains a constant differential pressure across an external orifice, thereby regulating the hydraulic flow rate across this external orifice (see table for pressure ranges). When used with an orifice as described above, it functions as a bypass type regulator, delivering pump flow through the external orifice.

**FEATURES**

- Hardened parts for long life.
- Industry common cavity.

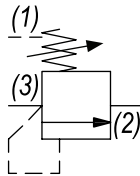
**HYDRAULIC SYMBOL**

*Can be used as an adjustable logic element. Great as an adjustable pressure setting regulation device in brake, transmission & cooling systems, because the spring chamber is separately drained, the outlet can be used for lower pressure functions. For fixed version see DF-PCR-oP. For higher spring differential pressure ranges consult factory.*

**PERFORMANCE**

Actual Test Data (Cartridge Only)

300 PSI setting / Regulated Flow vs Inlet Pressure

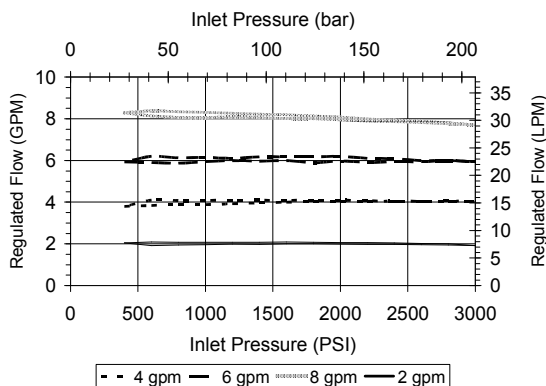
**VALVE SPECIFICATIONS**

Nominal Flow	10 GPM (38 LPM)
Rated Operating Pressure	3500 PSI (241 bar)
Seat Ratio	Area of Pilot is equal to the area at Port (3)
Viscosity Range	36 to 3000 SSU (3 to 647 cSt)
Filtration	ISO 18/16/13
Media Operating Temp. Range	-40° to 250°F (-40° to 120°C)
Weight	.52 lbs (.23 kg)
Operating Fluid Media	General Purpose Hydraulic Fluid
Cartridge Torque Requirements	30 ft-lbs (40.6 Nm)
Cavity	DELTA 3W
Cavity Form Tool (Finishing)	40500001
Seal Kit	21191210

**WARNING:** the specifications/application data shown in our catalogs and data sheets are intended only as a general guide for the product described (herein). Any specific application should not be undertaken without independent study, evaluation, and testing for suitability.

**DIMENSIONS**

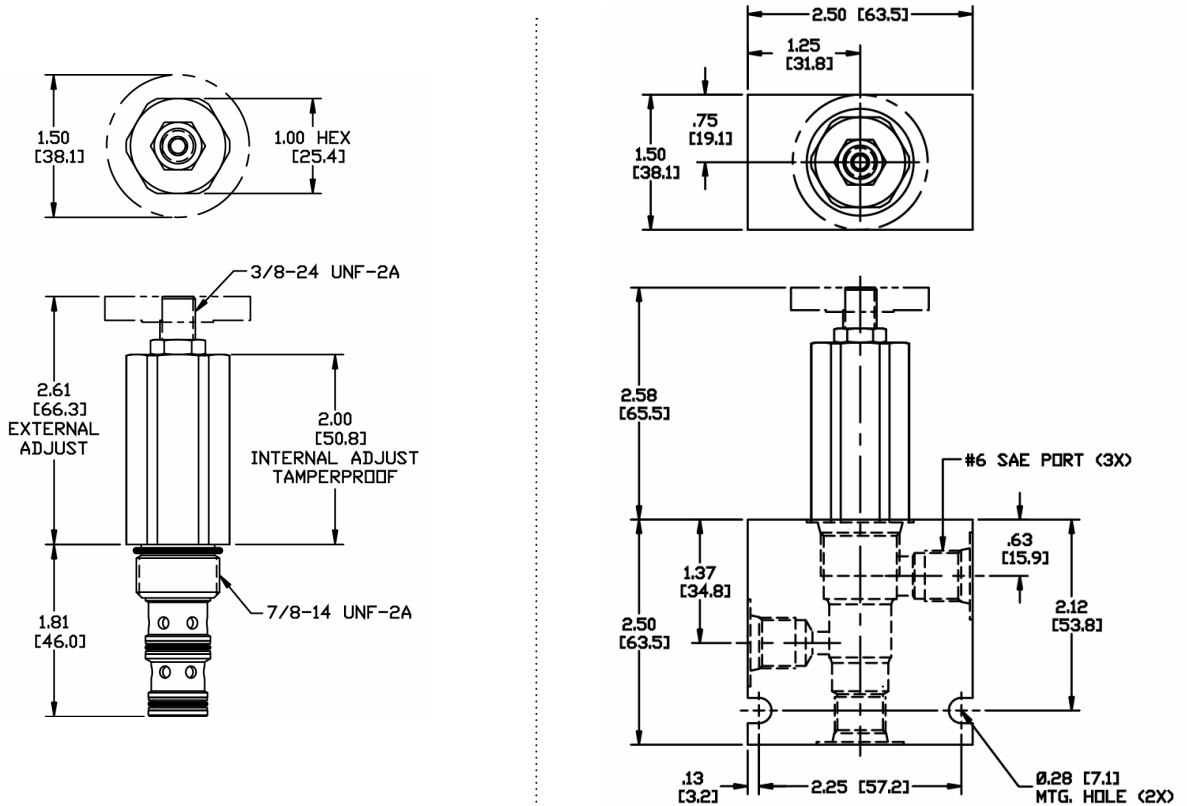

Body Weight: .76 lbs (.35 kg)

**ORDERING INFORMATION**

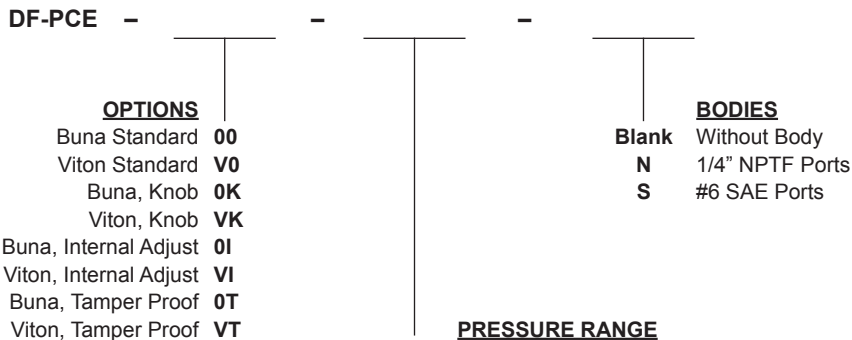

**0300** **PRESSURE RANGE**  
100 - 300 PSI

Differential Pressure Across  
External Controlling Orifice

**Tamper Proof**  
Fill in 4 Digit Pressure Setting  
Example: 0200 - 200 PSI

W/51 / 12-2022

**WARNING:** the specifications/application data shown in our catalogs and data sheets are intended only as a general guide for the product described (herein). Any specific application should not be undertaken without independent study, evaluation, and testing for suitability.