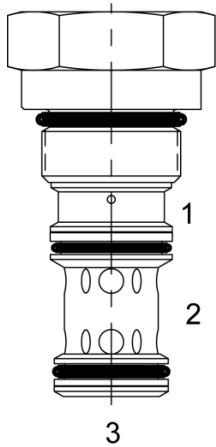

**TR-PCC PRESSURE COMPENSATING REGULATOR VALVE – RESTRICTIVE TYPE**

**DESCRIPTION**

12 size, 1 1/16-12 thread, "TWELVE" series, pressure compensating regulator valve (restrictive type).

**OPERATION**

The TR-PCC with an external orifice beyond port (3) and sensed by port (1) maintains a constant flow rate from (3) regardless of load pressure changes in the system downstream of (3), or in the inlet at (2) as long as pressure at (3) is greater than (1) by more than spring setting chosen and pump supply is in excess of demand. The valve's spool maintains a constant differential pressure across an external orifice, thereby regulating the hydraulic flow rate across this external orifice (see table for pressure ranges). When used with an orifice as described above, it functions as a restrictive type regulator, delivering pump flow through the external orifice. All ports may be fully pressurized.

**FEATURES**

- Hardened parts for long life.
- Industry common cavity.

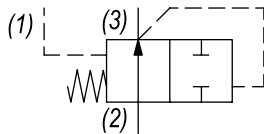
**HYDRAULIC SYMBOL**

*Can be used as a logic element. Fixed setting pressure reducing valve. For adjustable setting see TR-PCD.*

**PERFORMANCE**

Actual Test Data (Cartridge Only)

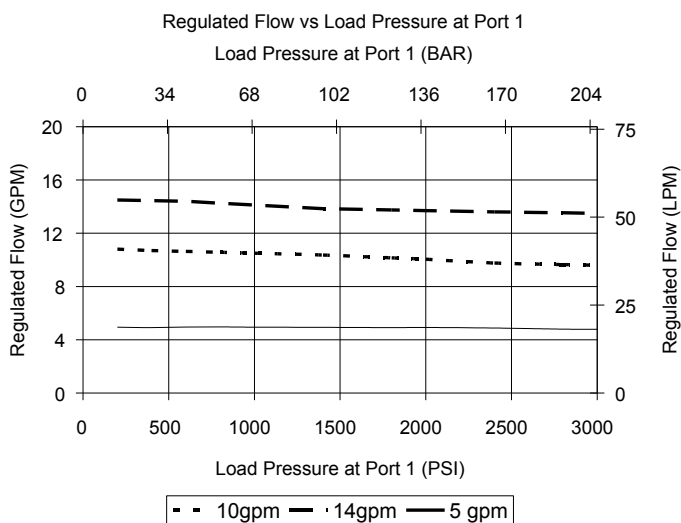
**VALVE SPECIFICATIONS**

Nominal Flow	20 GPM (76 LPM)
Rated Operating Pressure	3500 PSI (241 bar)
Seat Ratio	Area of Pilot is equal to the area at Port (3)
Viscosity Range	36 to 3000 SSU (3 to 647 cSt)
Filtration	ISO 18/16/13
Media Operating Temp. Range	-40° to 250°F (-40° to 120°C)
Weight	.54 lbs (.24 kg)
Operating Fluid Media	General Purpose Hydraulic Fluid
Cartridge Torque Requirements	70 ft-lbs (95 Nm)
Cavity	TWELVE 3WS
Cavity Form Tool (Finishing)	40500033
Seal Kit	21191306

**WARNING:** the specifications/application data shown in our catalogs and data sheets are intended only as a general guide for the product described (herein). Any specific application should not be undertaken without independent study, evaluation, and testing for suitability.

**DIMENSIONS**

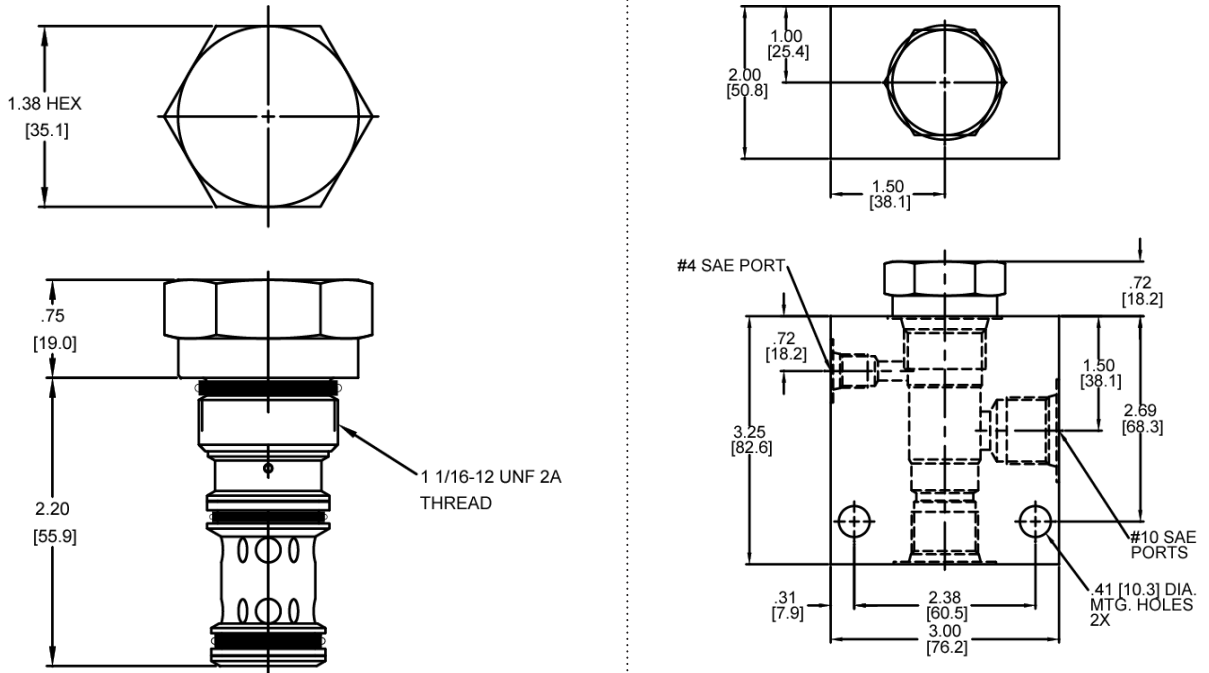

Body Weight: 1.56 lbs (.70 kg)

**ORDERING INFORMATION**

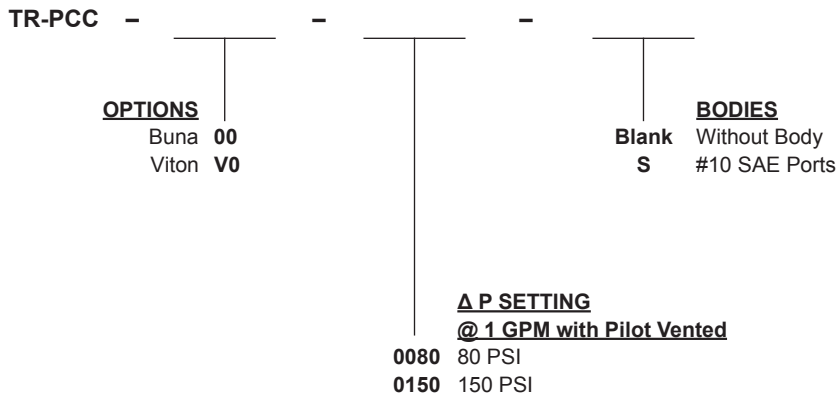

W-51 / 12-2022

**WARNING:** the specifications/application data shown in our catalogs and data sheets are intended only as a general guide for the product described (herein). Any specific application should not be undertaken without independent study, evaluation, and testing for suitability.